

Directional valve 2-way/2-position

$Q_{\max} = 140 \text{ l/min}$, $p_{\max} = 350 \text{ bar}$

pilot operated, poppet type, switching solenoid

Type series: WR22G_HA-10-...



- Screw-in cartridge valve
- For cavity DH
- All external parts with zinc-nickel plating according to DIN EN ISO 19598
- Seat tight shut-off
- The slip-on coil can be rotated, and it can be replaced without opening the hydraulic envelope
- High pressure wet-armature solenoids
- Various plug-connector systems and voltages are available
- Compact construction
- High flow rates
- Low head loss
- Reliable switching, even after long dwell times
- Installation in threaded port body type GCDHA

Description

The 2-way/2-position solenoid-operated directional seat valves, series WR22G..., are size 10, two stage, pressure balanced screw-in valves with a M27x2 mounting thread. The main and pilot stages are both designed on the poppet/seat principle, and the 2 to 1 flow path is therefore virtually leak-free. The straight-forward design delivers a good price/performance ratio and outstanding head loss/ flow ratings. All external parts of the screw-in valves are zinc-nickel plated and are thus suitable for use in the harshest opera-

ting environments. The slip-on coils can be replaced without opening the hydraulic envelope and can be positioned at any angle through 360°. These valves are primarily used as pilot valves in certain mobile and industrial applications where leak-tight shut-off functions are crucially important. Examples are where loads, tensions, or clamping forces must be held without leakage. For self-assembly, please refer to the section related data sheets.

Symbol

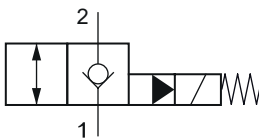

Technical data

General characteristics	Description, value, unit
Sales category	minimum order quantity required (see order details)
Function group	Directional valve
Function	2-way/2-position
Design	Screw-in cartridge valve
Controls	switching solenoid
Characteristic	pilot operated, poppet type
Construction size	NG 10
Thread size	M27×2
Mounting attitude	unrestricted
Weight	0.57 kg
Cavity acc. ISO	fits into ISO 7789: 27-01-0-07
Cavity acc. factory standard	For cavity DH
Tightening torque steel	80 Nm
Tightening torque tolerance	± 10 %
Minimum ambient temperature	- 30 °C
Maximum ambient temperature	+ 50 °C
Surface protection	All external parts with zinc-nickel plating according to DIN EN ISO 19598
Sealing material	see ordering code
Seal kit order number	NBR: DS-367-N / FKM: DS-367-V

Hydraulic characteristics	Description, value, unit
Maximum operating pressure	350 bar
Maximum flow rate	140 l/min
Flow direction	see symbol
Hydraulic fluid	HL and HLP mineral oil according to DIN 51 524; other fluids on request!
Minimum fluid temperature	- 30 °C
Maximum fluid temperature	+ 80 °C
Viscosity range	10 ... 500 mm ² /s (cSt)
Recommended viscosity range	15 ... 250 mm ² /s (cSt)
Minimum fluid cleanliness (cleanliness class according to ISO 4406:1999)	class 20/18/15



NOTE!

The switching safety of the valve is achieved by the volume flow and pressure drop (Δp).

Electric characteristics	Description, value, unit
Actuator type	solenoid coil
Solenoid coils type	D36
Supply voltage DC	12/24 V DC
Supply voltage AC	115/230 (50 ... 60 Hz) V AC
Supply voltage tolerance	± 10 %
Nominal power consumption	Version "E": V DC = 17 W / V AC = 17 W Version "N": V DC = 27 W / V AC = 25 W
Switching time	Version "E": 30...90 ms (energized) / 75...220 ms (de-energized) Version "N": 25...130 ms (energized) / 50...200 ms (de-energized)
Relative duty cycle	100 %
Electrical connection coil	several connection types available, see ordering code
Protection class solenoid coil to ISO 20 653 / EN 60 529	several classes of protection available, see ordering code (with appropriate mating connector and proper fitting and sealing)



NOTE!

The switching time can be strongly dependent on flow rate, pressure, oil viscosity and the dwell time under pressure. In practice, the switching time may therefore deviate from the specified value range.

Performance graphs

measured with oil viscosity 33.0 mm²/s (cSt), coil at steady-state temperature and 10 % undervoltage

$p = f(Q)$ Performance limit

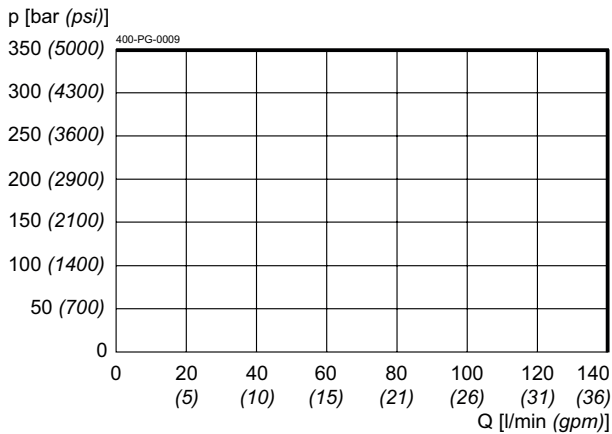

$\Delta p = f(Q)$ Pressure drop-flow rate characteristic

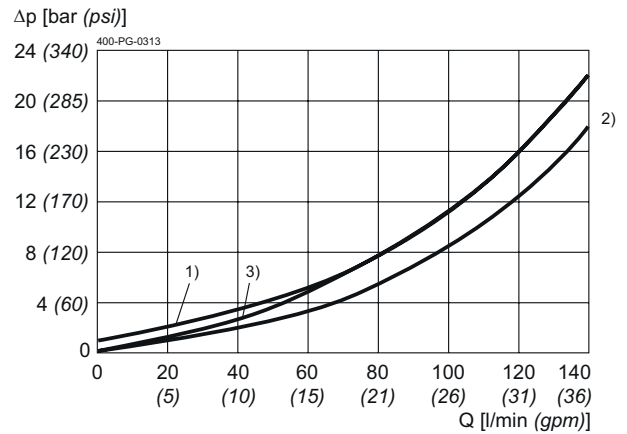

- 1) 1 → 2, solenoid de-energized
- 2) 2 → 1, solenoid energized
- 3) 1 → 2, solenoid energized

Dimensions and sectional view

Beispiel für die Masseinheit:
Example for the dimensional units:
0.79 = 0.79 mm millimeter
(.031) = 0.031" inch

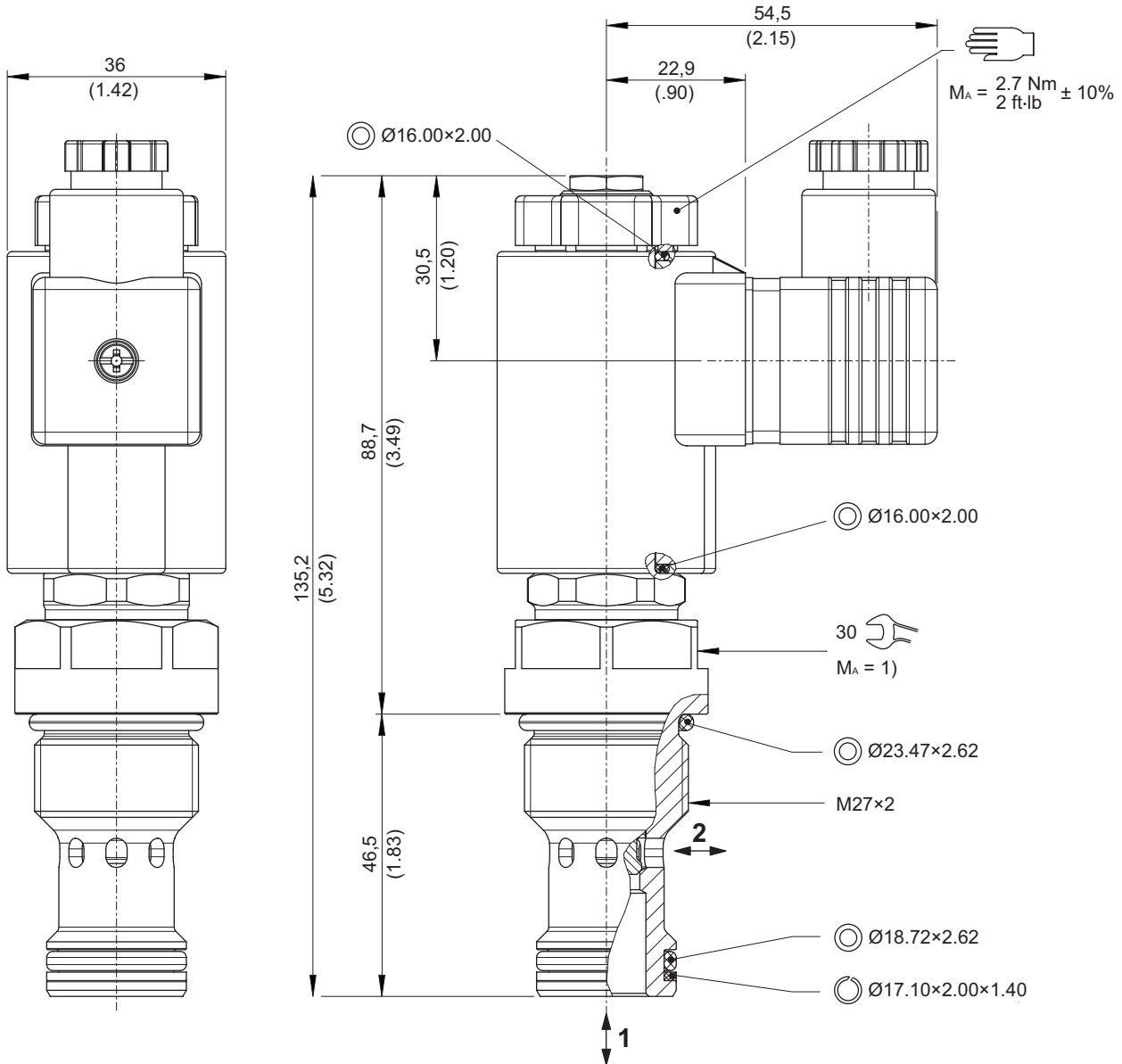

Installation information

- i NOTE!**
1) When fitting the screw-in cartridge valve, use the specified tightening torque. The value can be found in the chapter "Technical data".
- i NOTE!**
The seals are not available individually. The seal kit order number can be found in the chapter "Technical data".

! ATTENTION!
Only qualified personnel with mechanical skills may carry out any maintenance work. Generally, the only work that should ever be undertaken is to check, and possibly replace, the seals. When changing seals, oil or grease the new seals thoroughly before fitting them.

Ordering code

Ex.

W	R	22G	E	H	A	-	10	-	1	-	24	D	-
---	---	-----	---	---	---	---	----	---	---	---	----	---	---

<p>W = directional valve</p> <p>R = check valve function, pilot operated</p> <p>22G = 2-way/2-position, normally closed</p> <p>E = electrically operated, V DC = 17 W / V AC = 17 W (standard)</p> <p>N = electrically operated, V DC = 27 W / V AC = 25 W</p> <p>H = cavity type DH</p> <p>A ... Q = standard model - see relevant data sheets</p> <p>Z ... R = special features - please consult BUCHER</p> <p>10 = nominal size 10</p> <p>(ohne) = NBR (nitril-butadien-rubber / BUNA) seals (standard)</p> <p>V = FKM (fluorocarbon rubber / VITON) seals <i>(Spezial-Dichtungen nach Rücksprache)</i></p> <p>1 ... 9 = technical design no. (omit when ordering)</p> <p>... = voltage e.g. 24 (24 V)</p> <p>D = current DC</p> <p>A = current AC</p> <p>(blank) = DIN EN 175301-803 connection, 3-pole 2 P+E with mating plug (IP 65) (standard)</p> <p>M100 = DIN EN 175301-803 connection, 3-pole 2 P+E</p> <p>C = Kostal plug connection (IP 65)</p> <p>JT = Junior Timer radial plug connection (with protection diode, IP 65)</p> <p>IT = Junior Timer axial plug connection (with protection diode, IP 65)</p> <p>D = Deutsch plug connection 45° DT04-2P (IP 67/69K)</p> <p>DT = Deutsch plug connection 45° DT04-2P (with protection diode, IP 67/69K)</p> <p>S = AMP Superseal 1.5 (IP 67) / Metri-Pack 150 (IP 65) plug connection</p> <p>F = flying leads (500 mm)</p>	<p style="text-align: right;">} mating plug not supplied</p>
---	--



IMPORTANT!

Minimum order quantity of 500 pcs/year

Related data sheets

Reference	Description
400-P-040011	Form tools
400-P-060171	Cavity DH
400-P-740161	Threaded port body GCDHA
400-P-120110	Solenoid coil D36

info.ch@bucherhydraulics.com

www.bucherhydraulics.com

© 2024 by Bucher Hydraulics AG Frutigen, 3714 Frutigen, Switzerland

All rights reserved.

Data is provided for the purpose of product description only, and must not be construed as warranted characteristics in the legal sense. The information does not relieve users from the duty of conducting their own evaluations and tests. Because the products are subject to continual improvement, we reserve the right to amend the product specifications contained in this catalogue.